

# **Water v Glucose:** **Why do they give** **different rates?**

Becca Asquith, Imperial College London

# Outline

- Introduction –stable isotope labelling
- The problem
- Investigating explanations
  - ❖ Inaccurate peak timing
  - ❖ Rapid cell loss
  - ❖ Saturation
  - ❖ Non-constant  $d$
  - ❖ Normalization
- Summary

# Introduction

# Stable Isotope Labelling

- Widely used to quantify cell kinetics
- Two commonly used methods – deuterated glucose or deuterated water

# Glucose

- Rapid labelling & delabelling
- Short label pulse: 24-48h

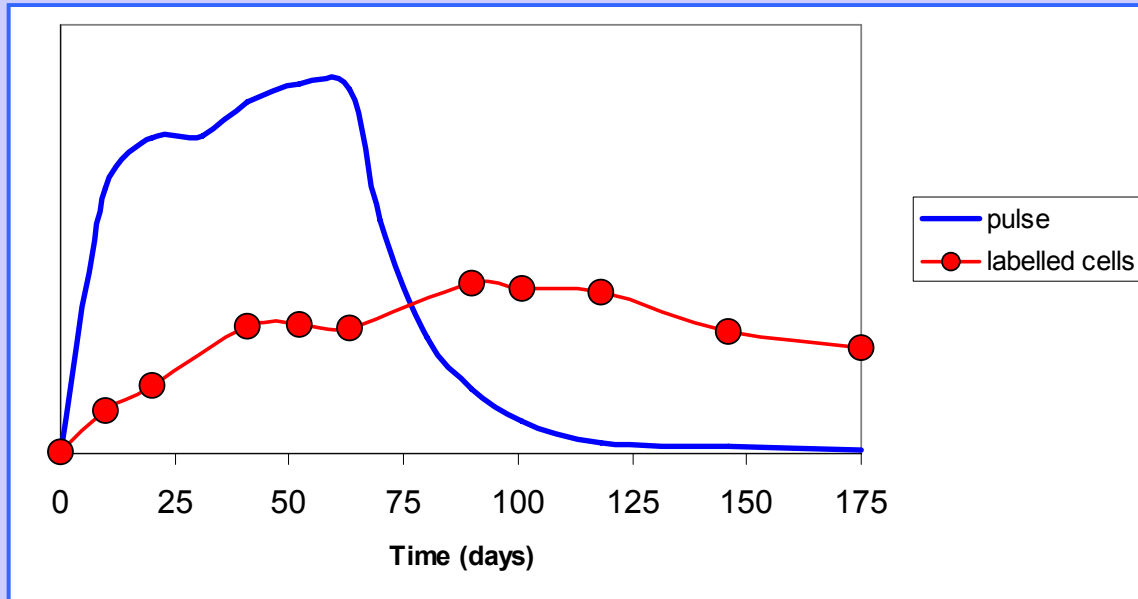
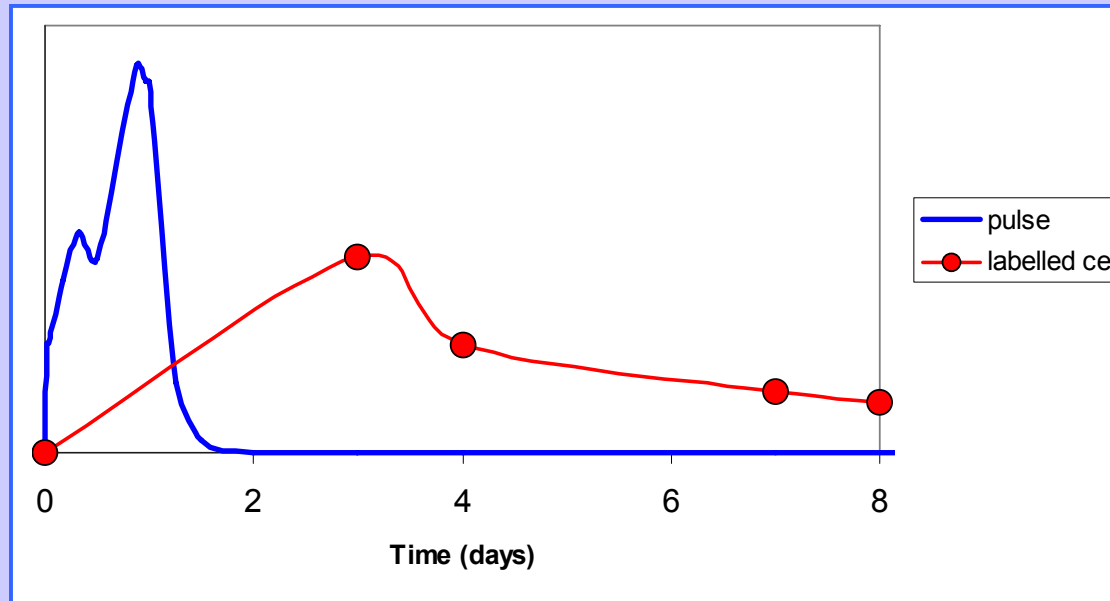

# Water

- Slow labelling & delabelling
- Long label pulse: 60-80days

**Problem**

# Kinetics of CD8<sup>+</sup> & CD4<sup>+</sup> Memory T cells

Proliferation rate CD8+CD45RO+

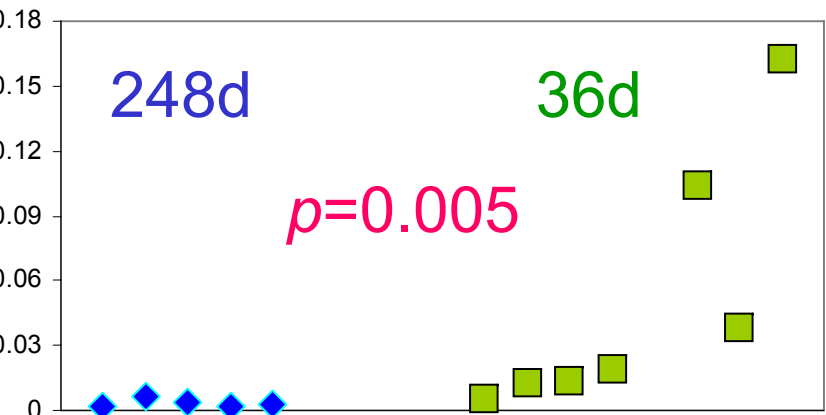

Proliferation rate CD4+CD45RO+

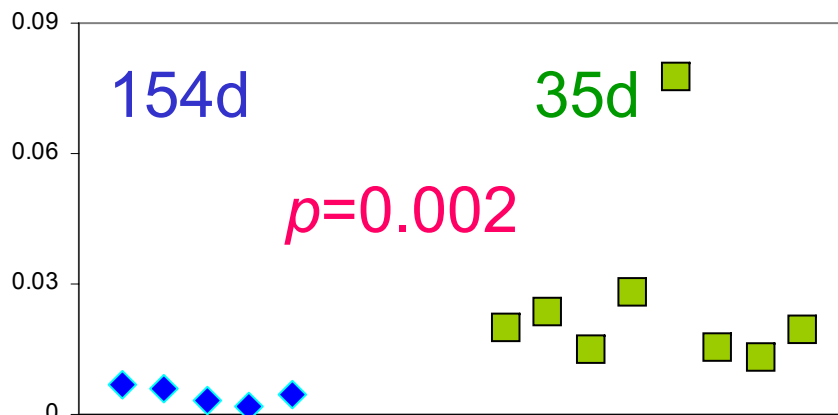

Disappearance rate CD8+CD45RO+

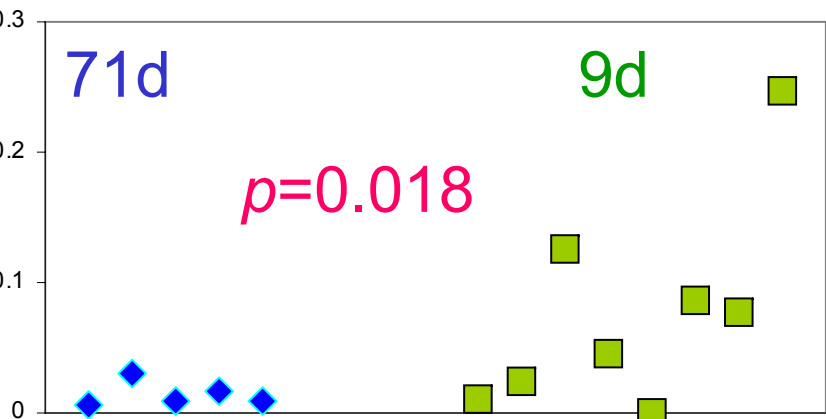

Disappearance rate CD4+CD45RO+

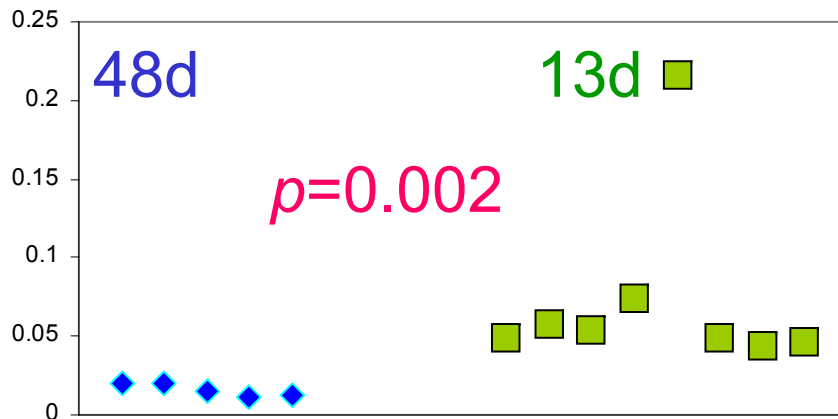

◆ Water  
■ Glucose

N Vrisekoop *et al* PNAS 08  
D Macallan *et al* E.J. 03

# Difference in death rates is expected

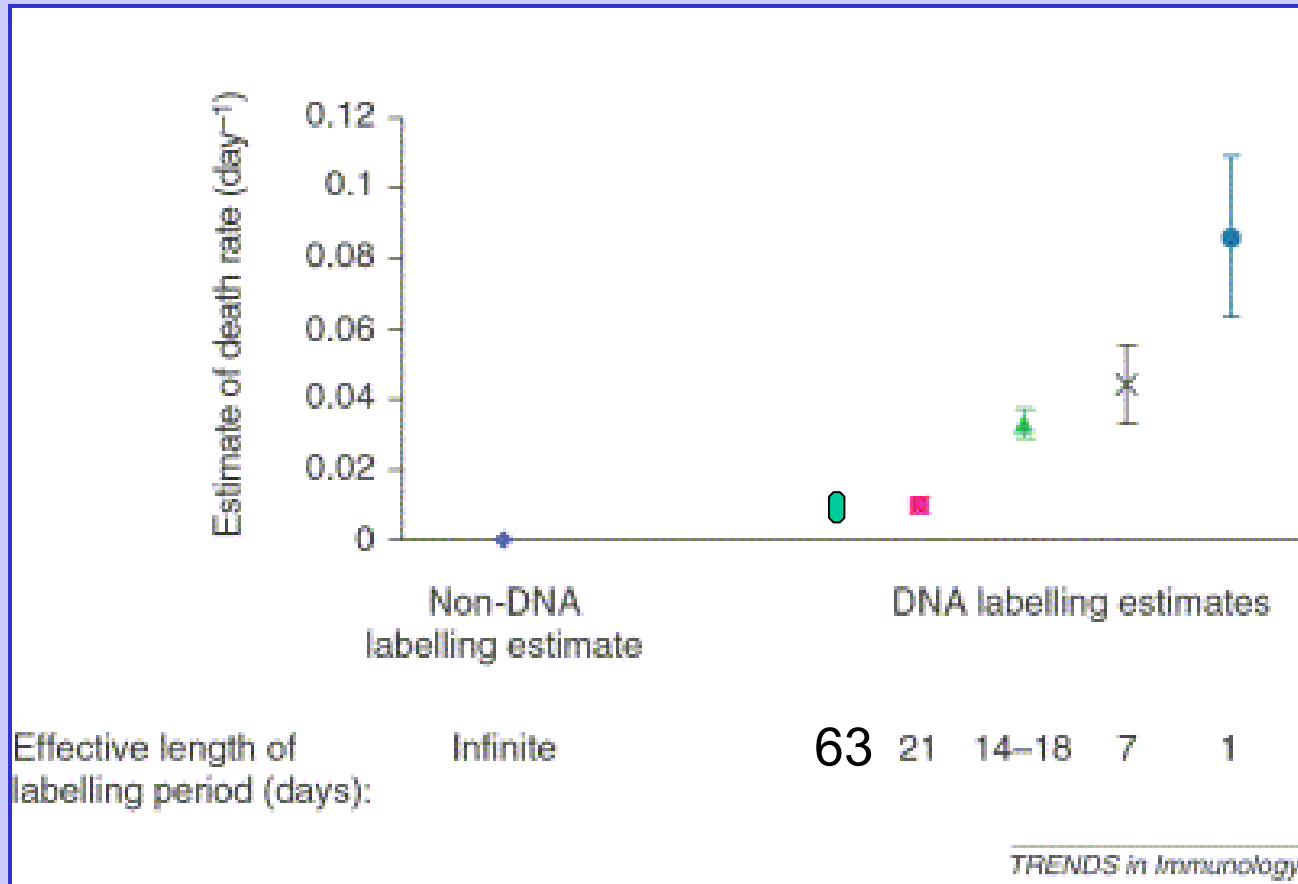

# Glucose consistently overestimates the rate of cell proliferation

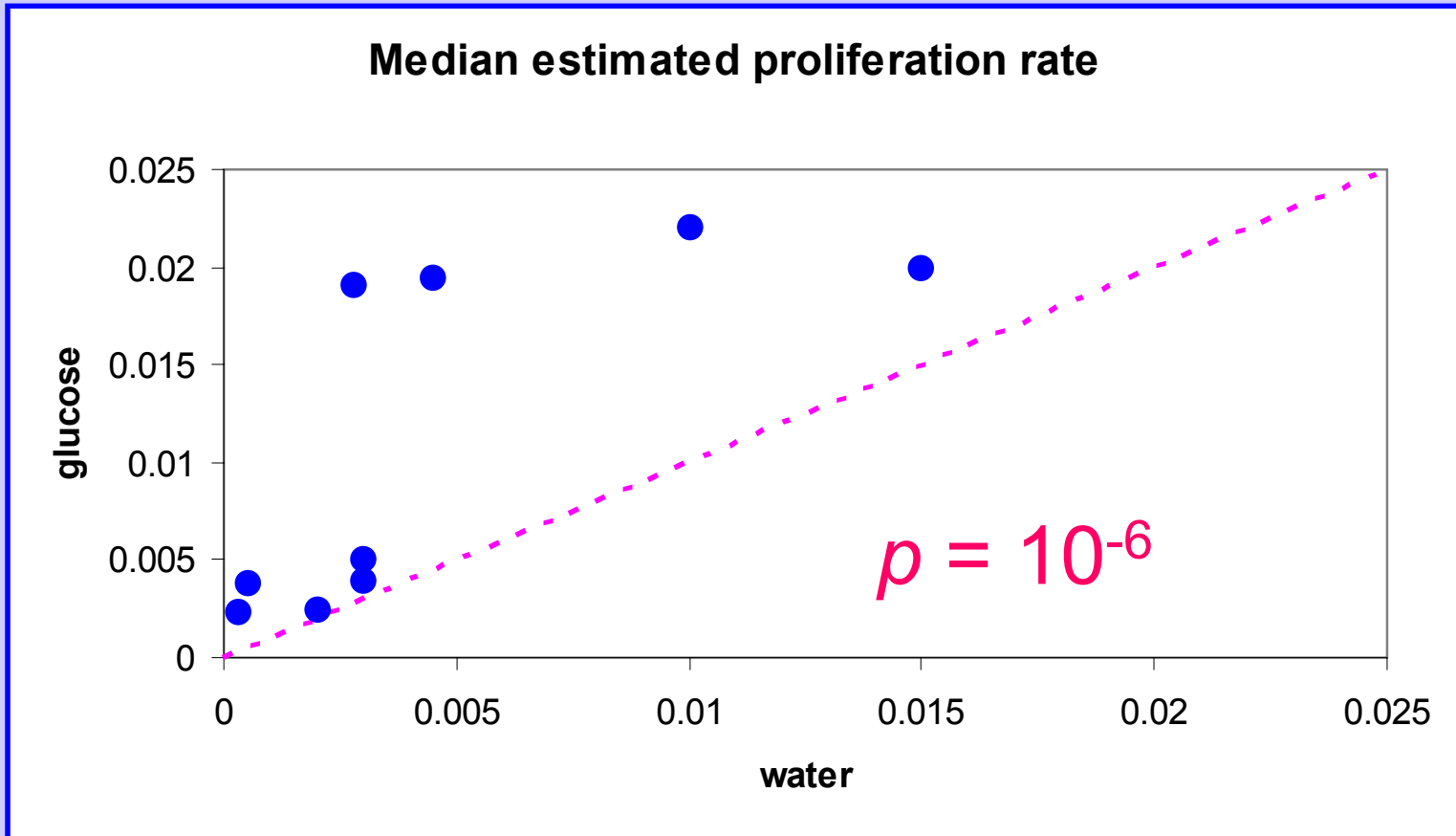

# Possible explanations

- ❖ Inaccurate peak timing
- ❖ Rapid cell loss
- ❖ Saturation

# Glucose

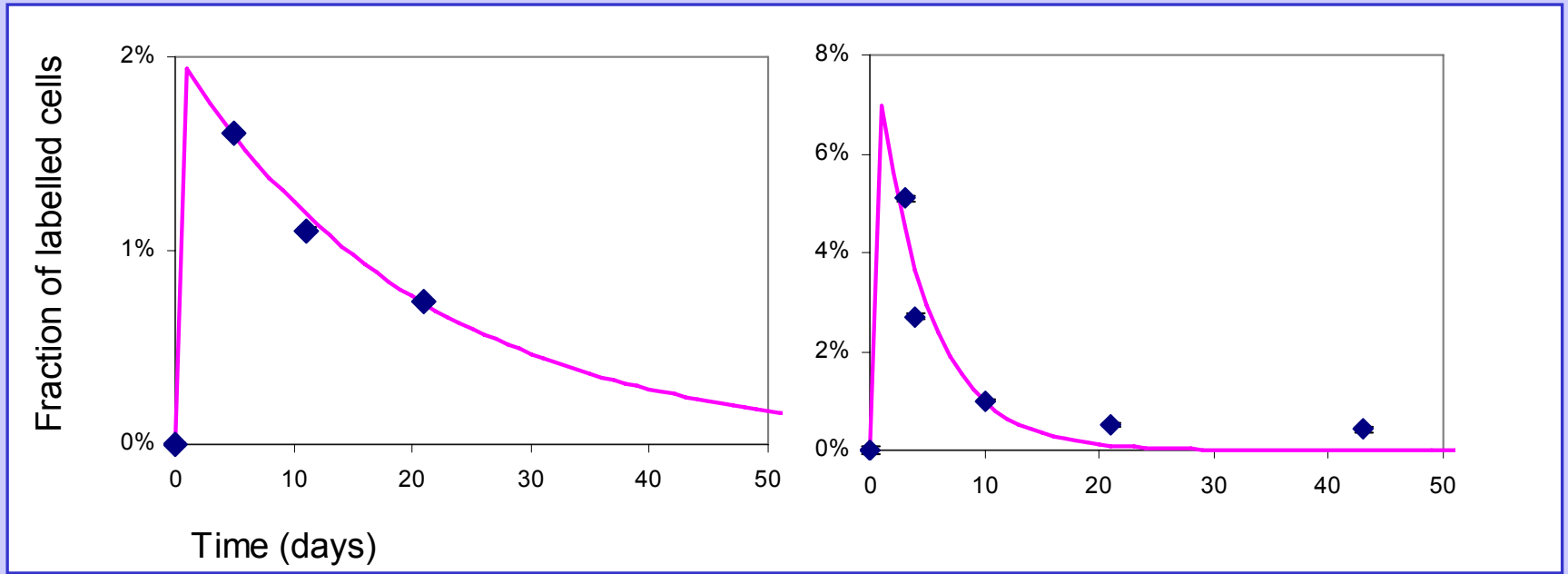

**CD8 CD45RO proliferation rate**

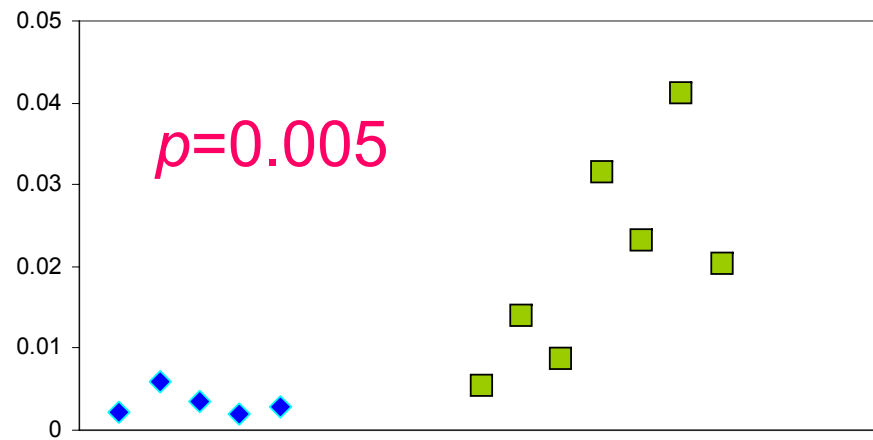

**CD4 CD45RO proliferation rate**

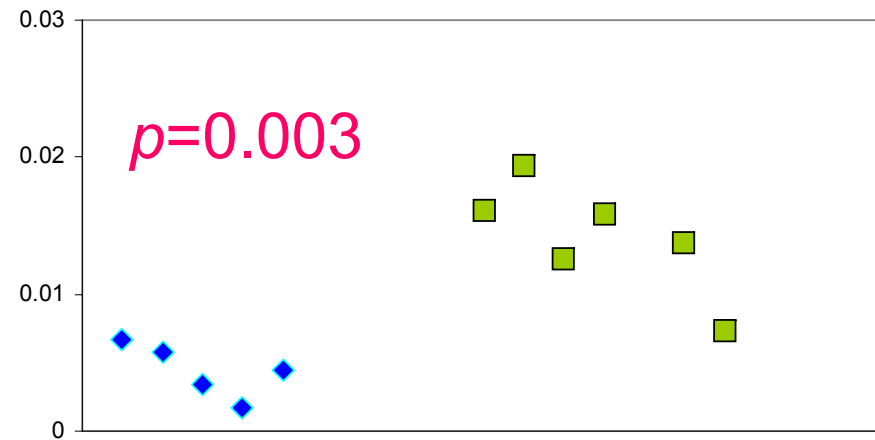

# Conclusion 1

- Inaccurate peak timing cannot explain the majority of the observed discrepancy

# Possible explanations

- ❖ Inaccurate peak timing
- ❖ Rapid cell loss
- ❖ Saturation

# In silico labelling

- Choose an underlying model of cell kinetics

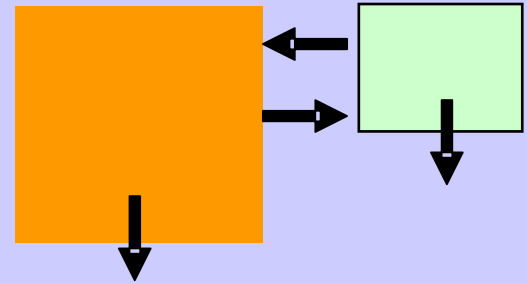
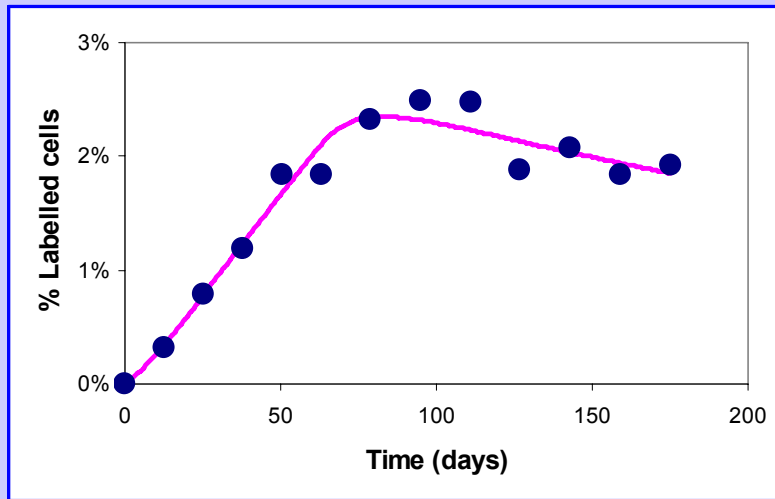

- Label the model in silico
- Fit the “data”
- Compare estimated & known proliferation rate

# Underlying models

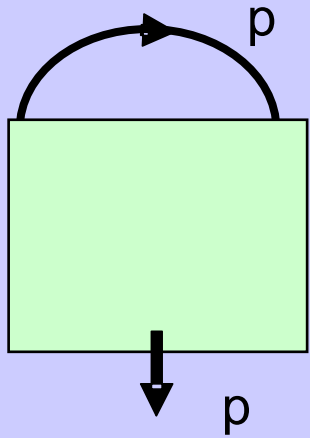

1) Simple homogeneous population  $p=d$

2) 2 populations  $p_1=d_1$ ,  
 $p_2=d_2$

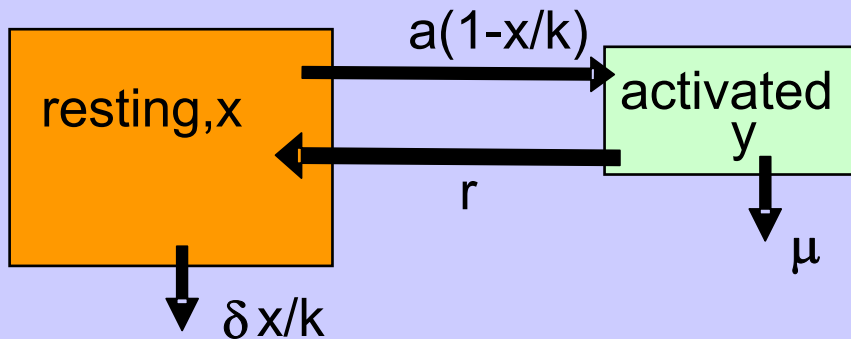
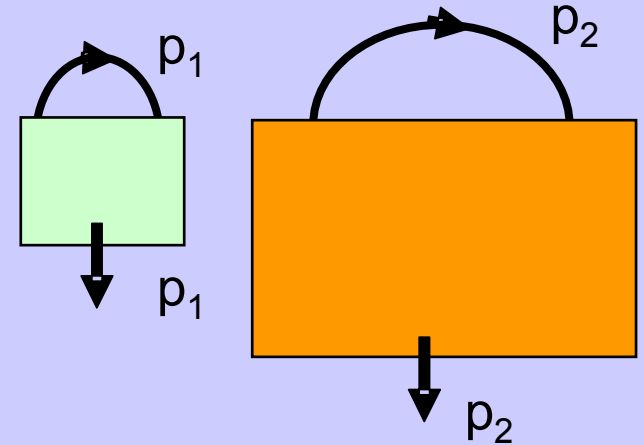

3) Resting & activated

Yates et al 2001 Disc C Dyn Sys

# Possible explanations

- ❖ Inaccurate peak timing
- ❖ Rapid cell loss
- ❖ Saturation

# Rapid Cell Loss:

## Can you capture rapid kinetics with a slow label?

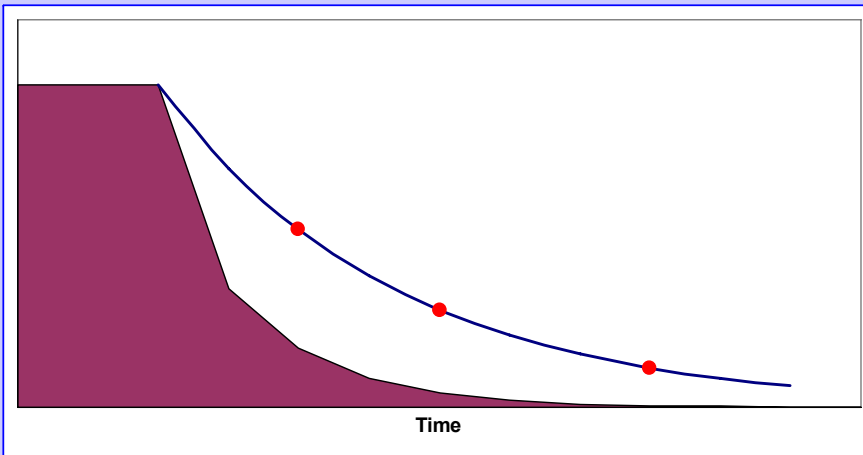

Cell loss slow compared with loss of label

-no problem

Cell loss rapid compared with loss of label

-underestimate cell loss?  
&  $\therefore$  cell proliferation?

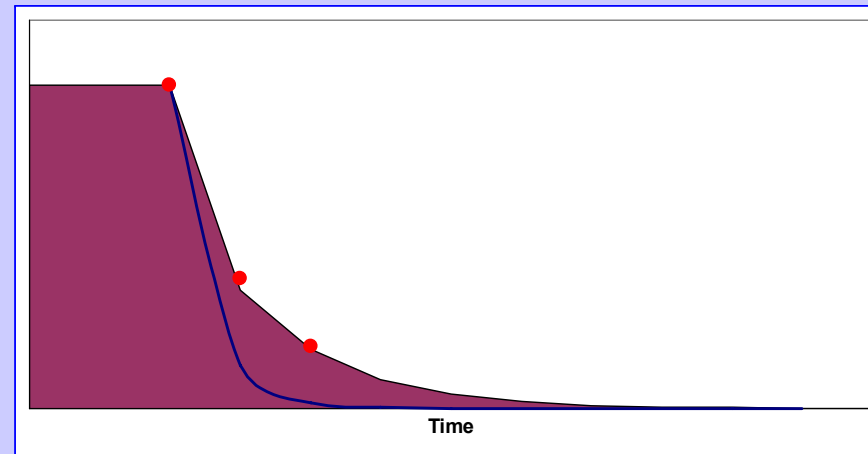

# Can you capture rapid kinetics with a slow label?

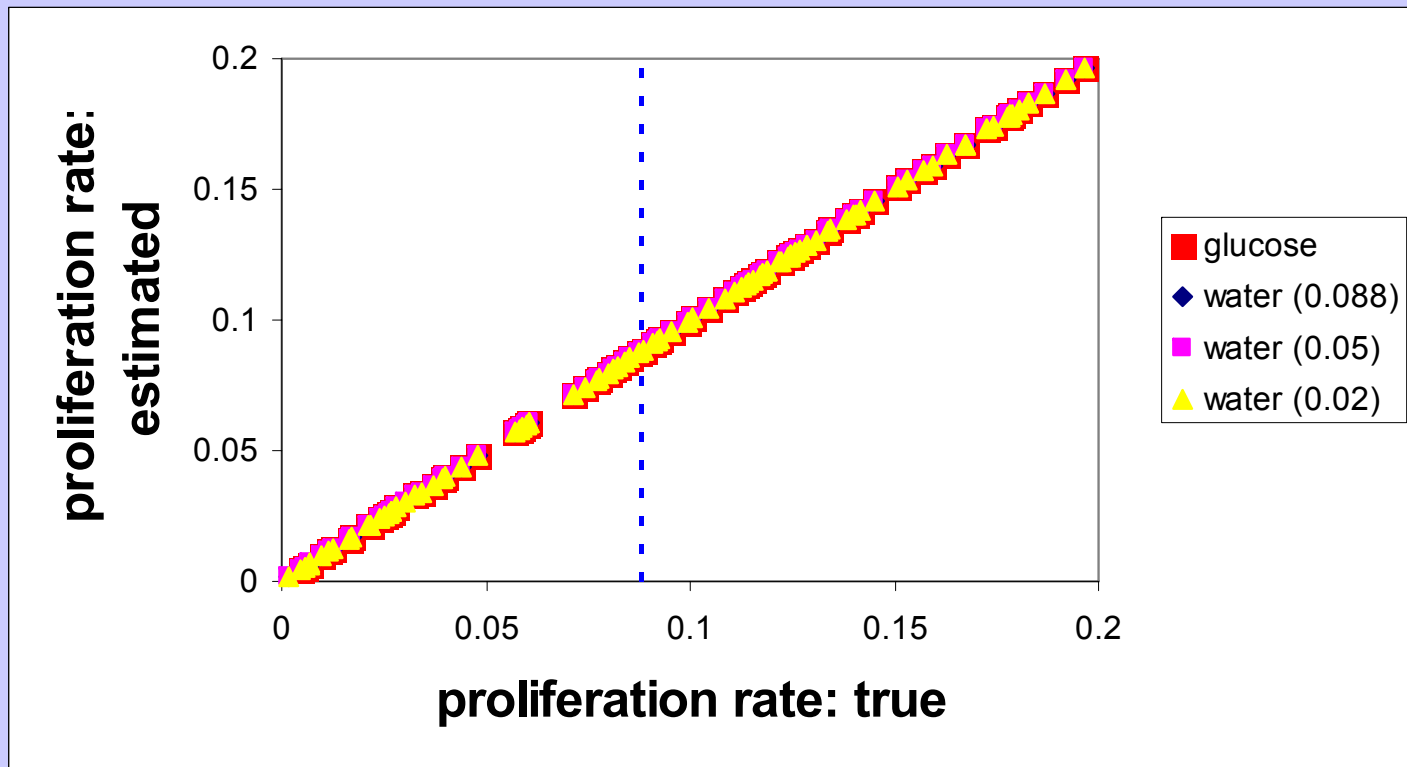

# Conclusion 2

- No problem quantifying rapid dynamics with a slow label

# Possible explanations

- ❖ Inaccurate peak timing
- ❖ Rapid cell loss
- ❖ Saturation
- ❖ Non-constant  $d$

# Saturation:

rapidly turning over subpopulation 100%  
labelled

=>

underestimate average proliferation rate

# If saturation was significant

1) Expect

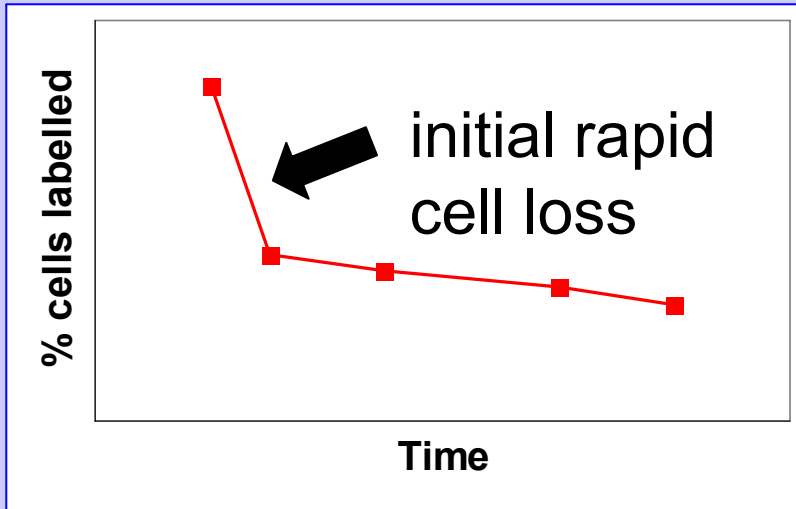

Observe

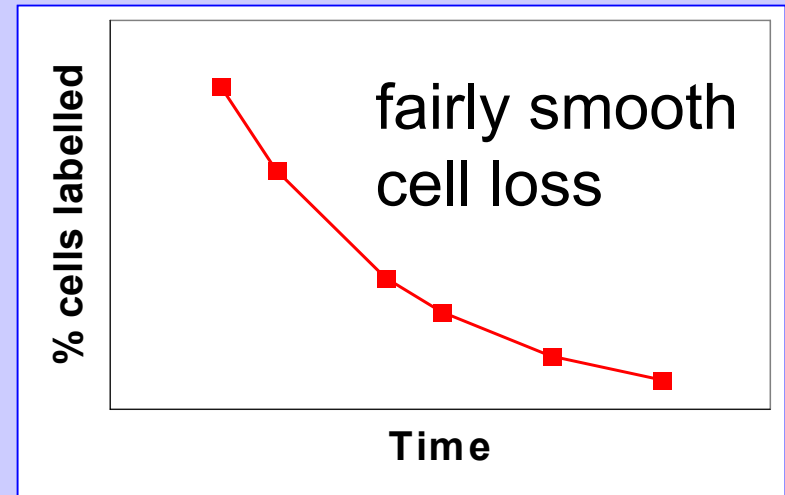
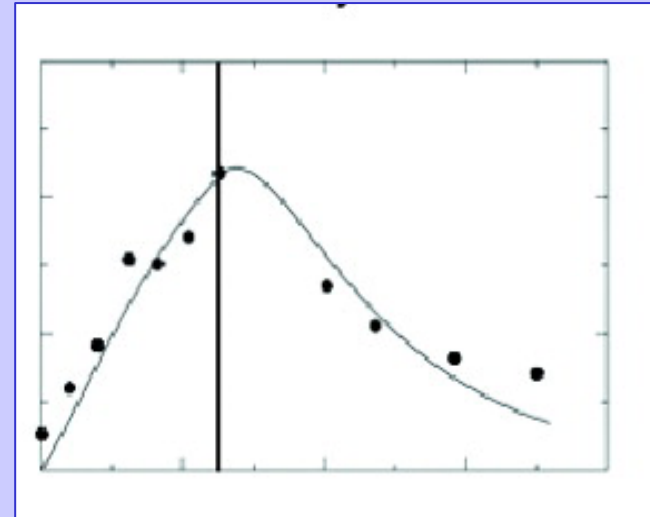

# If saturation was significant

2) Expect

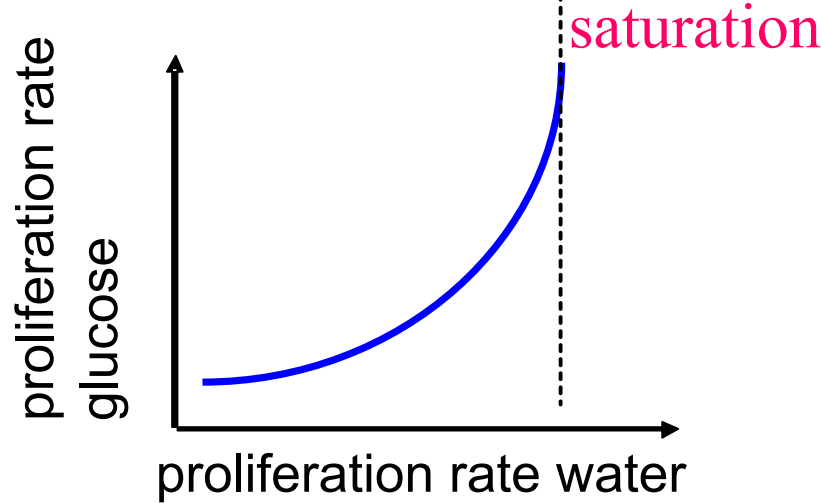

Observe

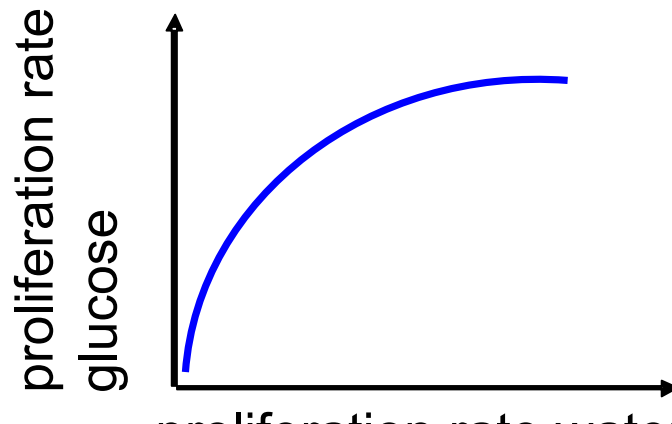
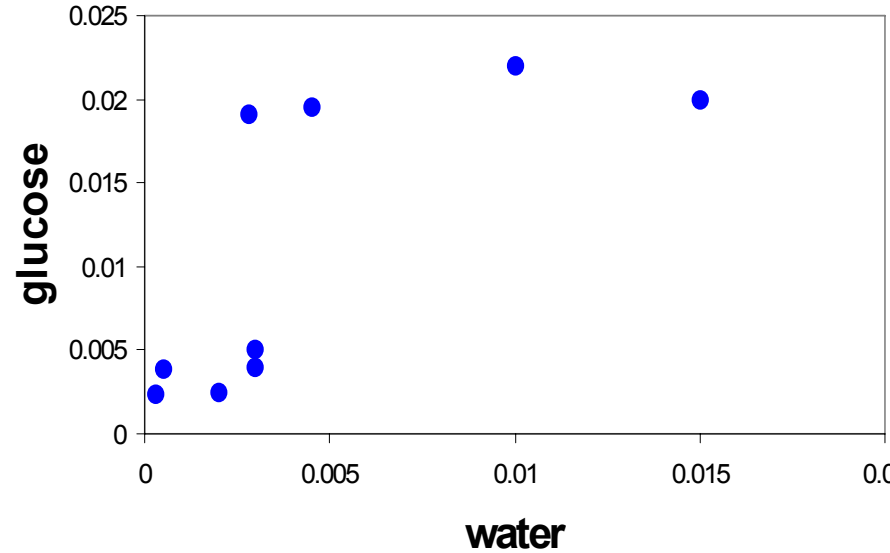

# Saturation work: aim

- Can saturation lead to an underestimate of cell proliferation?
- Is there any way to reconcile significant saturation with the two observations:

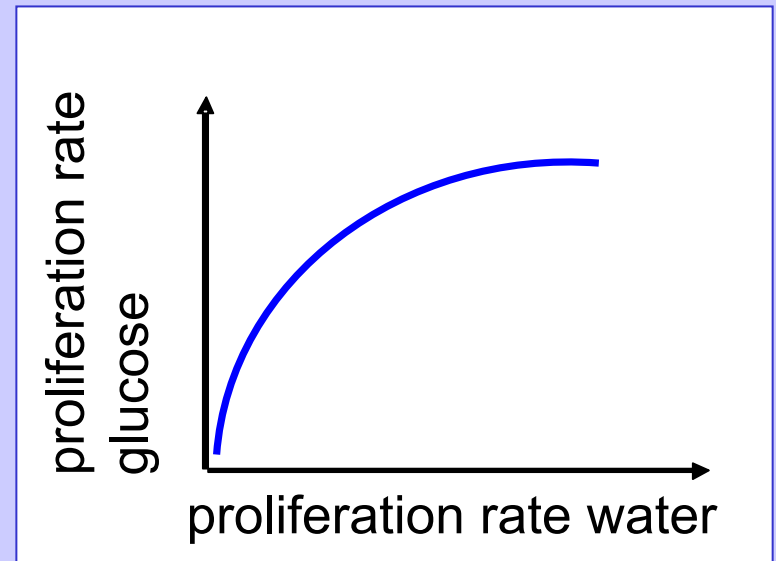
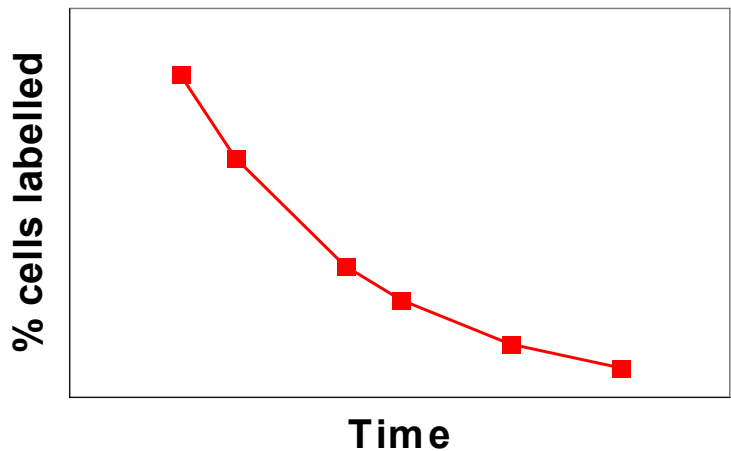

# Two population model

Varying the labelling period

All other parameters constant

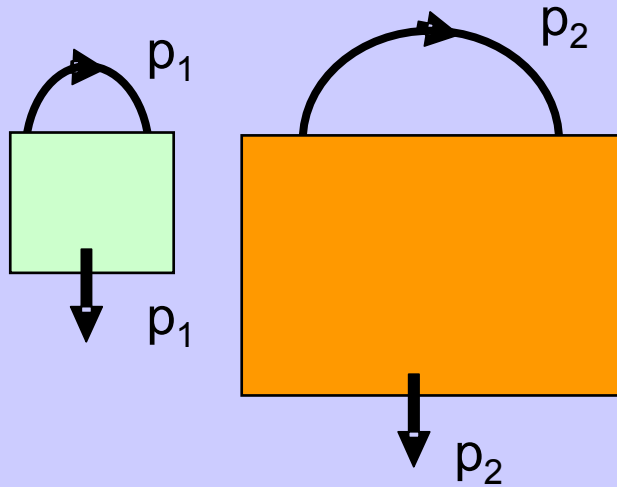

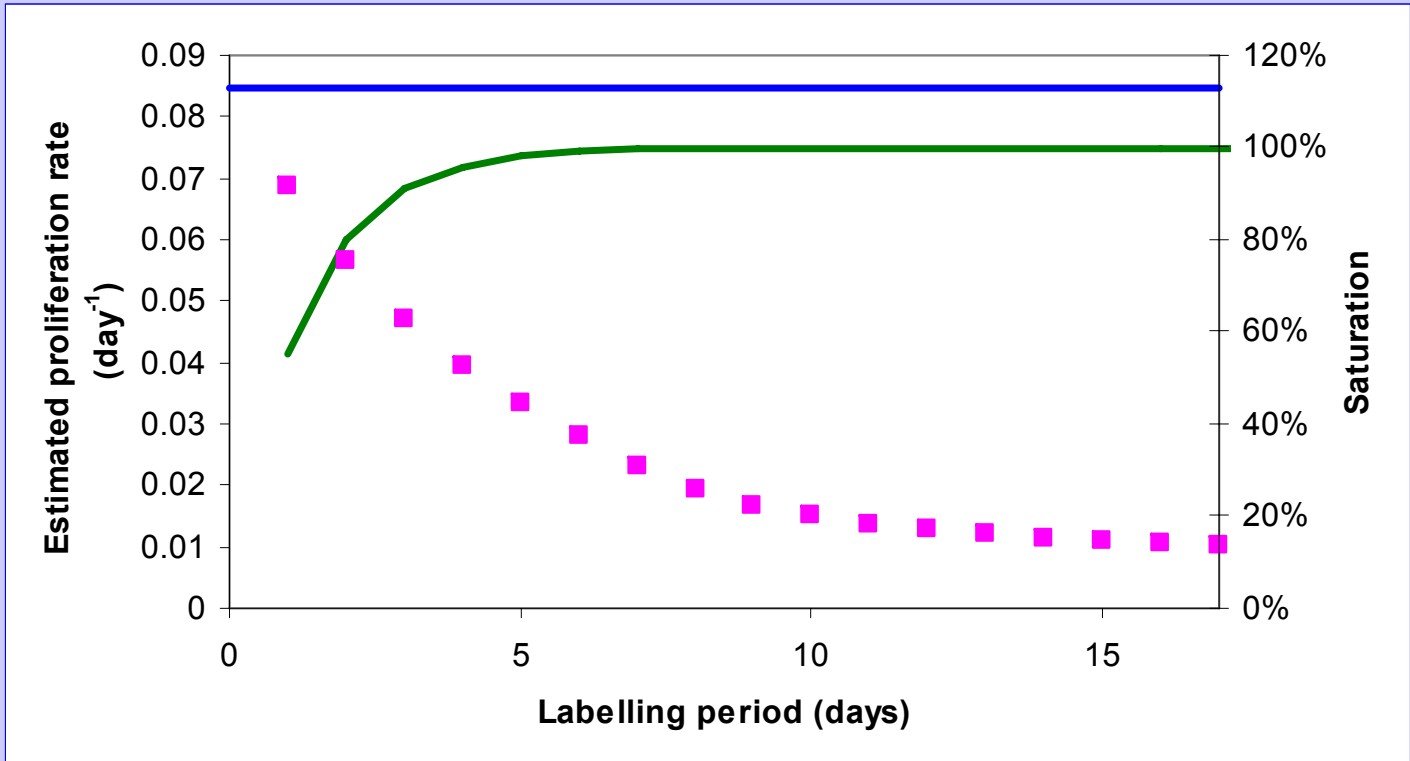

- True proliferation rate
- Saturation
- Estimated proliferation rate

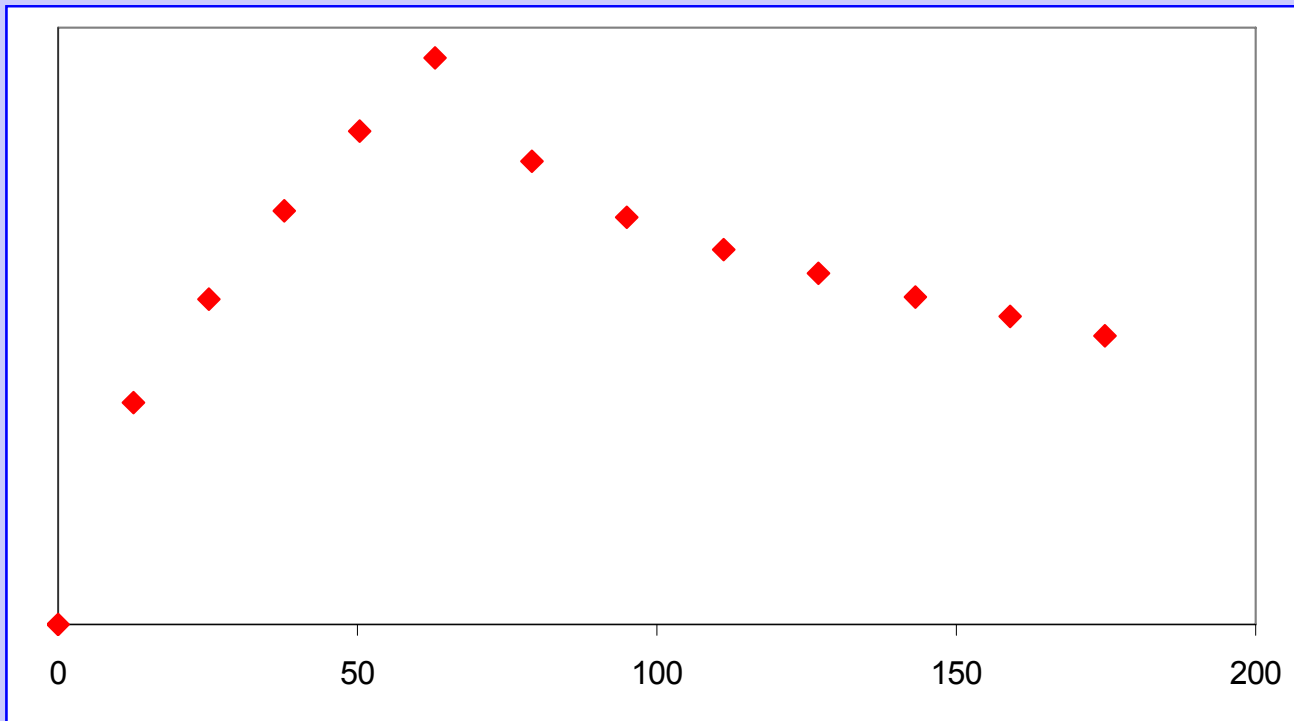

Change in delabelling slope within the observed range

Estimated parameters within observed range

100% saturation, 88% underestimate of proliferation

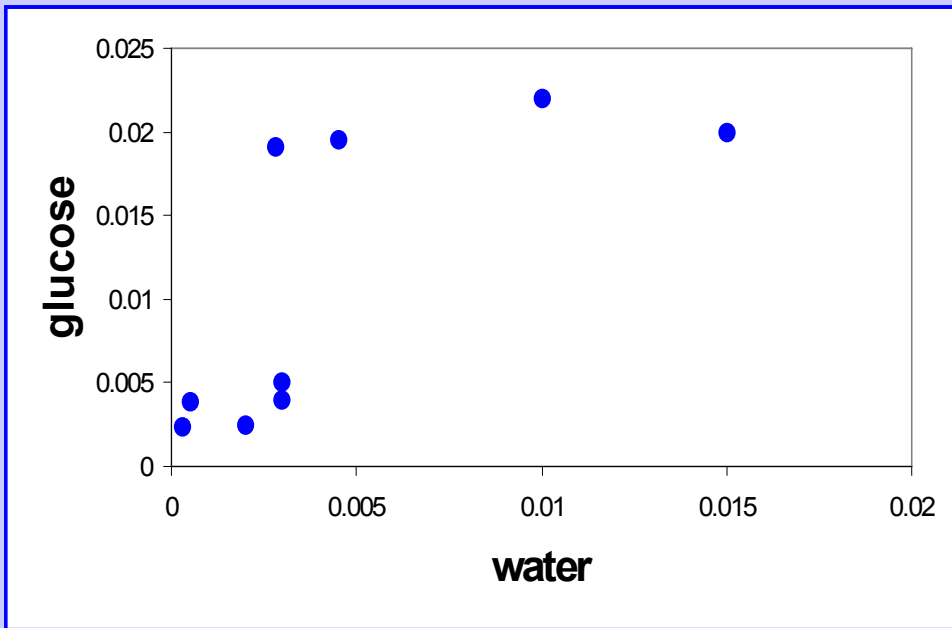

Under what situations can you obtain this type of pattern?

- Activated cells have a similar proliferation rate
- Resting cells have a similar proliferation rate

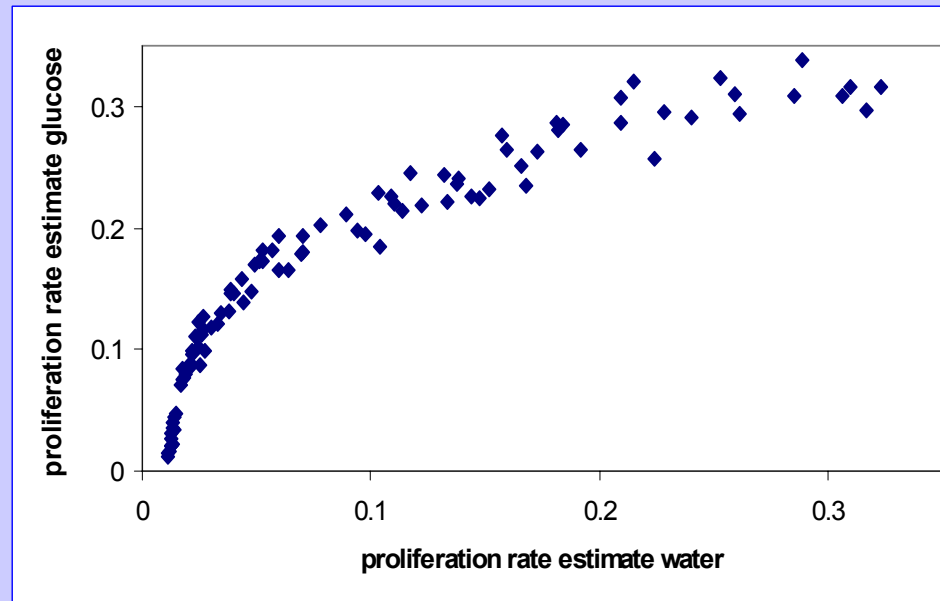

# Conclusion 3

- Saturation can lead to severe underestimate of proliferation rates
- These observations are not necessarily inconsistent with saturation

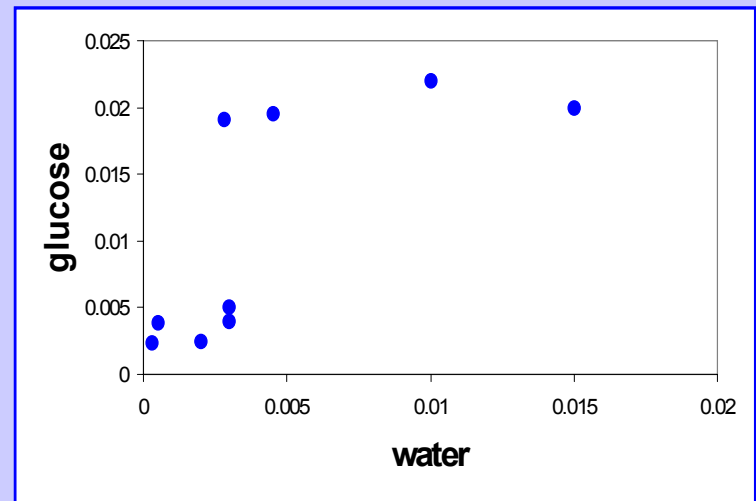
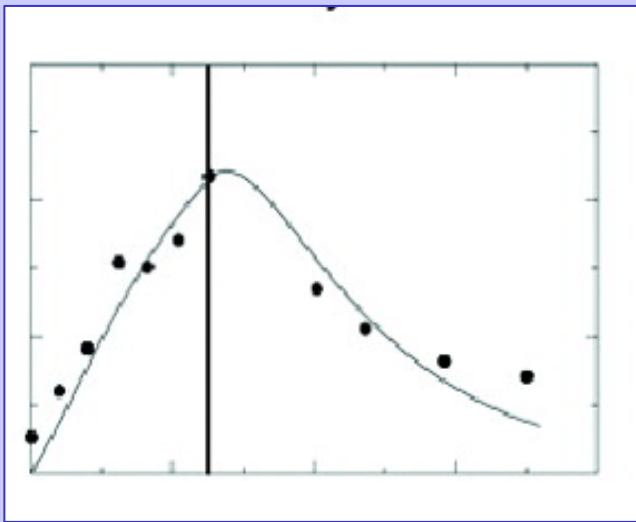

# What next?

- Extend the work on saturation
- Investigate non-constant  $d$  & normalization
- Devise experimental test

# Conclusions

- Estimates of death and proliferation rates differ systematically
- Not explained by peak mistiming (back extrapolation) in glucose experiments
- Not explained by slow kinetics of heavy water
- Saturation a possible candidate but more work needs to be done

# Acknowledgements

Derek Macallan

José Borghans

Nienke Vrisekoop

Luc Willems

Vitaly Ganusov

Julien Defoiche

Charles Bangham

Rob de Boer

Frank Miedema

MRC, RCUK, Wellcome Trust